

Gril Horizontal mod GHPI **F5/1450**

Dimensiones:

1450mm (w) x 850mm (h) x 550mm (p)

Peso: 205 kg

Caudal termico: 30,80 kw

Tipo: A

Categoría: II_{2H3+}

Tension: 230 V

Potencia eléctrica: 44 w

Gas Butano

Pression - 28-30 mbar

Consumo - 2,5 kg/h

Gas Propano

Pression - 37 mbar

Consumo - 2,5 kg/h

Gas Natural

Pression - 20 mbar

Consumo - 3,3 m³/h

Encastrable



raspador

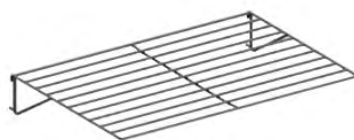

GRE.F2.P71
rejilla extra



GRE.F5.P70
suport para rejillas

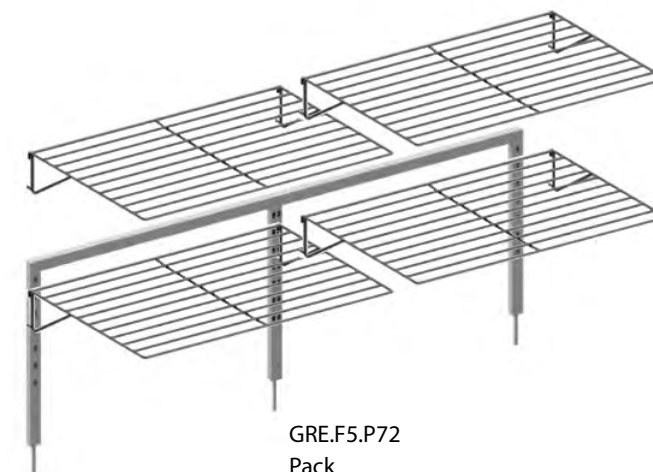

GRE.F5.P72
Pack

Gril Horizontal mod GHPI **F5/1450**

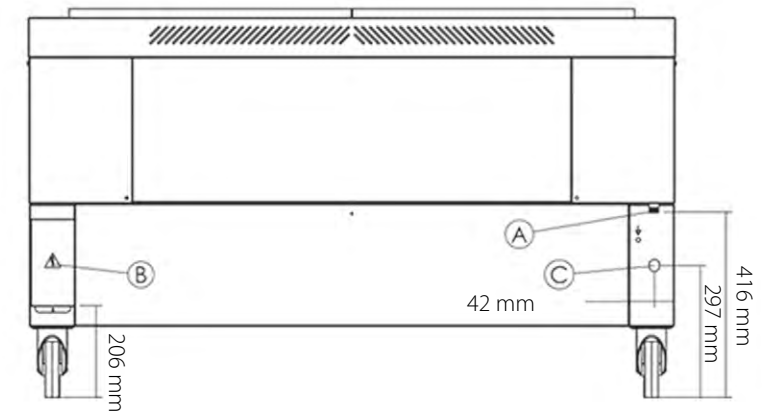
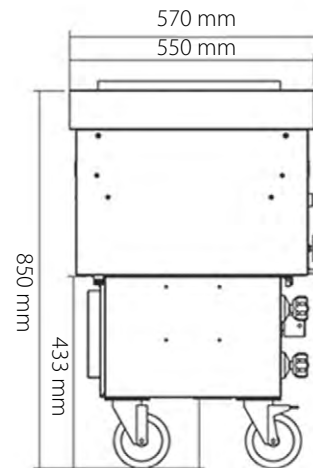
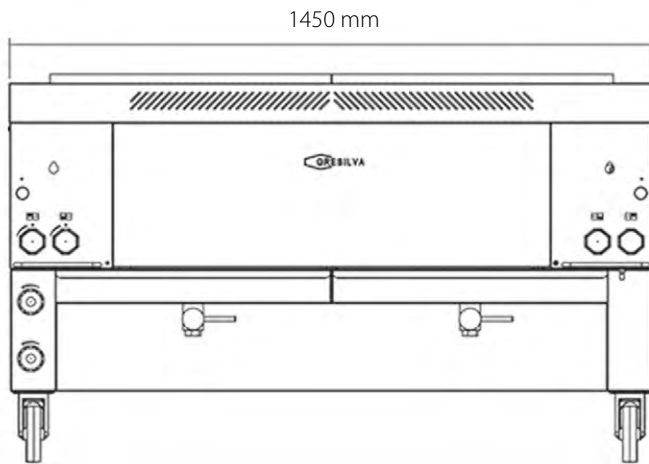

- A - entrada del gas 1/2"
- B - salida del cable de alimentación
- C - entrada de agua 3/4"

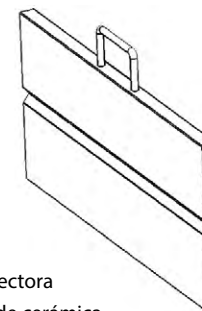
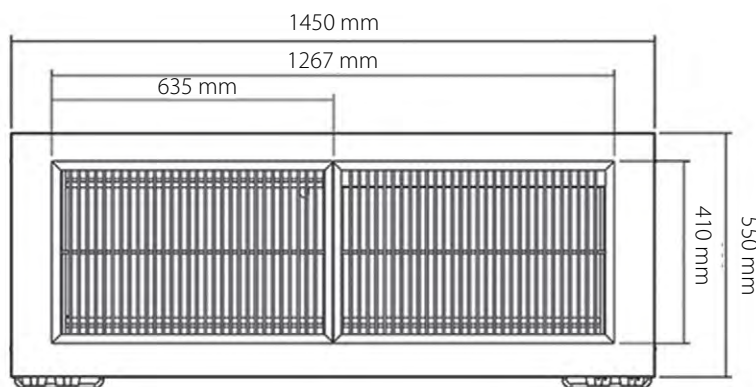

Placa protectora
de platos de cerámica

